

JSD-80 Connection to CM-35 Monitor Balanced to Unbalanced Wiring Method

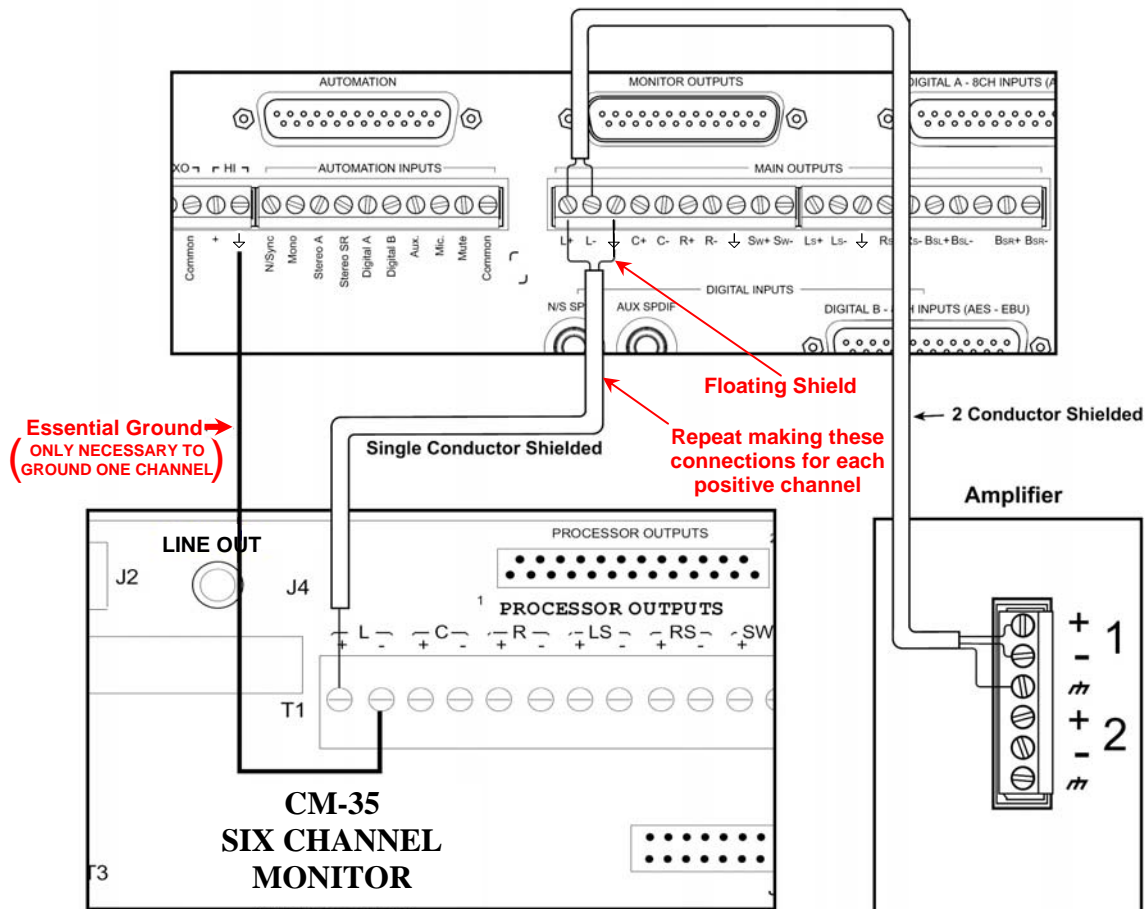

NOTE:

This is a typical wiring diagram for each channel of the JSD-80 outputs. Connecting the "L-" side of the balanced output to an older monitor with unbalanced inputs will short the "L-" signal to ground and cause hum, noise, and the loss of 6dB of level. Please follow the above diagram.