

(a) R_N equals the amount of reimbursement.

(b) C equals the actual cost of relocating the link(s). Actual relocation costs include, but are not limited to, such items as: Radio terminal equipment (TX and/or RX—antenna, necessary feed lines, MUX/Modems); towers and/or modifications; back-up power equipment; monitoring or control equipment; engineering costs (design/path survey); installation; systems testing; FCC filing costs; site acquisition and civil works; zoning costs; training; disposal of old equipment; test equipment (vendor required); spare equipment; project management; prior coordination notification under § 101.103(d) of this chapter; site lease renegotiation; required antenna upgrades for interference control; power plant upgrade (if required); electrical grounding systems; Heating Ventilation and Air Conditioning (HVAC) (if required); alternate transport equipment; and leased facilities. Increased recurring costs represent part of the actual cost of relocation and, even if the compensation to the incumbent is in the form of a commitment to pay five years of charges, the AWS or MSS/ATC relocater is entitled to seek immediate reimbursement of the lump sum amount based on present value using current interest rates, provided it has entered into a legally binding agreement to pay the charges. C also includes voluntarily relocating microwave incumbent's independent third party appraisal of its compensable relocation costs and incumbent transaction expenses that are directly attributable to the relocation, subject to a cap of two percent of the "hard" costs involved. Hard costs are defined as the actual costs associated with providing a replacement system, such as equipment and engineering expenses. C may not exceed \$250,000 per paired link, with an additional \$150,000 permitted if a new or modified tower is required.

(c) N equals the number of AWS and MSS/ATC entities that have triggered a cost-sharing obligation. For the AWS relocater, $N = 1$. For the next AWS entity triggering a cost-sharing obligation, $N = 2$, and so on. In the case of a voluntarily relocating microwave incumbent, $N = 1$ for the first AWS entity

triggering a cost-sharing obligation. For the next AWS or MSS/ATC entity triggering a cost-sharing obligation, $N = 2$, and so on.

(d) T_m equals the number of months that have elapsed between the month the AWS or MSS/ATC relocater or voluntarily relocating microwave incumbent obtains reimbursement rights for the link and the month in which an AWS entity triggers a cost-sharing obligation. An AWS or MSS/ATC relocater obtains reimbursement rights for the link on the date that it signs a relocation agreement with a microwave incumbent. A voluntarily relocating microwave incumbent obtains reimbursement rights for the link on the date that the incumbent notifies the Commission that it intends to discontinue, or has discontinued, the use of the link, pursuant to § 101.305 of the Commission's rules.

§ 27.1166 Reimbursement under the Cost-Sharing Plan.

(a) *Registration of reimbursement rights.* Claims for reimbursement under the cost-sharing plan are limited to relocation expenses incurred on or after the date when the first AWS license is issued in the relevant AWS band (start date). If a clearinghouse is not selected by that date (see § 27.1162) claims for reimbursement (see § 27.1166) and notices of operation (see § 27.1170) for activities that occurred after the start date but prior to the clearinghouse selection must be submitted to the clearinghouse within 30 calendar days of the selection date.

(1) To obtain reimbursement, an AWS relocater must submit documentation of the relocation agreement to the clearinghouse within 30 calendar days of the date a relocation agreement is signed with an incumbent. In the case of involuntary relocation, an AWS relocater must submit documentation of the relocated system within 30 calendar days after the end of the relocation.

(2) To obtain reimbursement, a voluntarily relocating microwave incumbent must submit documentation of the relocation of the link to the clearinghouse within 30 calendar days of the date that the incumbent notifies the

Commission that it intends to discontinue, or has discontinued, the use of the link, pursuant to § 101.305 of the Commission's rules.

(b) *Documentation of expenses.* Once relocation occurs, the AWS relocater, or the voluntarily relocating microwave incumbent, must submit documentation itemizing the amount spent for items specifically listed in § 27.1164(b), as well as any reimbursable items not specifically listed in § 27.1164(b) that are directly attributable to actual relocation costs. Specifically, the AWS relocater, or the voluntarily relocating microwave incumbent must submit, in the first instance, only the uniform cost data requested by the clearinghouse along with a copy, without redaction, of either the relocation agreement, if any, or the third party appraisal described in (b)(1) of this section, if relocation was undertaken by the microwave incumbent. AWS relocaters and voluntarily relocating microwave incumbents must maintain documentation of cost-related issues until the applicable sunset date and provide such documentation upon request, to the clearinghouse, the Commission, or entrants that trigger a cost-sharing obligation. If an AWS relocater pays a microwave incumbent a monetary sum to relocate its own facilities, the AWS relocater must estimate the costs associated with relocating the incumbent by itemizing the anticipated cost for items listed in § 27.1164(b). If the sum paid to the incumbent cannot be accounted for, the remaining amount is not eligible for reimbursement.

(1) *Third party appraisal.* The voluntarily relocating microwave incumbent, must also submit an independent third party appraisal of its compensable relocation costs. The appraisal should be based on the actual cost of replacing the incumbent's system with comparable facilities and should exclude the cost of any equipment upgrades or items outside the scope of § 27.1164(b).

(2) *Identification of links.* The AWS relocater or the voluntarily relocating microwave incumbent must identify the particular link associated with appropriate expenses (*i.e.*, costs may not be averaged over numerous links).

Where the AWS relocater or voluntarily relocating microwave incumbent relocates both paths of a paired channel microwave link (*e.g.*, 2110–2130 MHz with 2160–2180 MHz and 2130–2150 MHz with 2180–2200 MHz), the AWS relocater or voluntarily relocating microwave incumbent must identify the expenses associated with each paired microwave link.

(c) *Full Reimbursement.* An AWS relocater who relocates a microwave link that is either fully outside its market area or its licensed frequency band may seek full reimbursement through the clearinghouse of compensable costs, up to the reimbursement cap as defined in § 27.1164(b). Such reimbursement will not be subject to depreciation under the cost-sharing formula.

(d) *Good Faith Requirement.* New entrants and incumbent licensees are expected to act in good faith in satisfying the cost-sharing obligations under §§ 27.1160 through 27.1174. The requirement to act in good faith extends to, but is not limited to, the preparation and submission of the documentation required in paragraph (b) of this section.

(e) *MSS Participation in the Clearinghouse.* MSS operators are not required to submit reimbursements to the clearinghouse for links relocated due to interference from MSS space-to-Earth downlink operations, but may elect to do so, in which case the MSS operator must identify the reimbursement claim as such and follow the applicable procedures governing reimbursement in part 27. MSS reimbursement rights and cost-sharing obligations for space-to-Earth downlink operations are governed by § 101.82 of this chapter.

(f) *Reimbursement for Self-relocating FMS links in the 2130–2150 MHz and 2180–2200 MHz bands.* Where a voluntarily relocating microwave incumbent relocates a paired microwave link with paths in the 2130–2150 MHz and 2180–2200 MHz bands, it may not seek reimbursement from MSS operators, but is entitled to reimbursement from the first AWS beneficiary for its actual costs for relocating the paired link, subject to the reimbursement cap in § 27.1164(b). This amount is subject to depreciation as specified in § 27.1164(b). An AWS licensee who is obligated to reimburse

§ 27.1168

relocation costs under this rule is entitled to obtain reimbursement from other AWS beneficiaries in accordance with §§ 27.1164 and 27.1168. For purposes of applying the cost-sharing formula relative to other AWS licensees that benefit from the self-relocation, depreciation shall run from the date on which the clearinghouse issues the notice of an obligation to reimburse the voluntarily relocating microwave incumbent.

[71 FR 29835, May 24, 2006, as amended at 78 FR 8270, Jan. 5, 2013]

§ 27.1168 Triggering a Reimbursement Obligation.

(a) The clearinghouse will apply the following test to determine when an AWS entity has triggered a cost-sharing obligation and therefore must pay an AWS relocater, MSS relocater, or a voluntarily relocating microwave incumbent in accordance with the formula detailed in § 27.1164:

(1) All or part of the relocated microwave link was initially co-channel with

the licensed AWS band(s) of the AWS entity or the selected assignment of the MSS operator that seeks and obtains ATC authority (see § 25.149(a)(2)(i) of this chapter);

(2) An AWS relocater, MSS relocater or a voluntarily relocating microwave incumbent has paid the relocation costs of the microwave incumbent; and

(3) The AWS or MSS entity is operating or preparing to turn on a fixed base station at commercial power and the fixed base station is located within a rectangle (Proximity Threshold) described as follows:

(i) The length of the rectangle shall be x where x is a line extending through both nodes of the microwave link to a distance of 48 kilometers (30 miles) beyond each node. The width of the rectangle shall be y where y is a line perpendicular to x and extending for a distance of 24 kilometers (15 miles) on both sides of x . Thus, the rectangle is represented as follows:

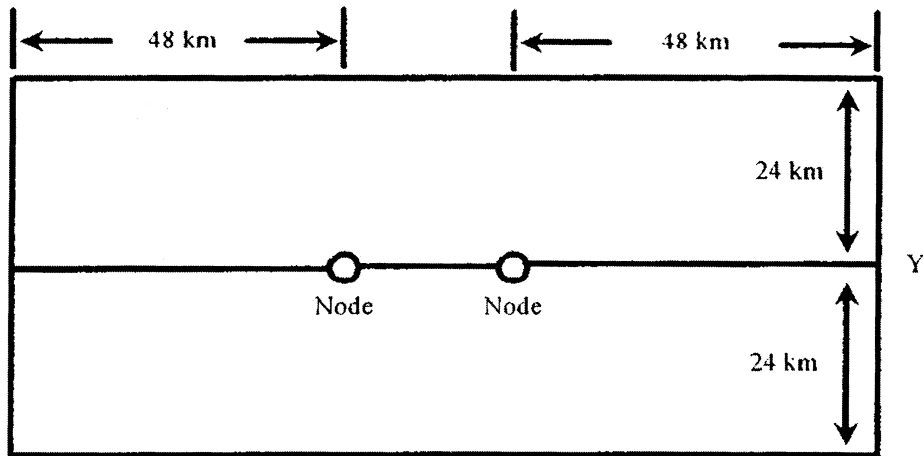

X

(ii) If the application of the Proximity Threshold Test indicates that a reimbursement obligation exists, the clearinghouse will calculate the reimbursement amount in accordance with

the cost-sharing formula and notify the AWS entity of the total amount of its reimbursement obligation.

(b) Once a reimbursement obligation is triggered, the AWS entity may not